

Light Duty
Spring Claw Latch

Model No	PAH-55-1547
Weight	0.060 Kgs
Holding Capacity	X - 0.50kN
Material	Steel
Finish	Zinc Plated
Model No	PAH-55-1547-SS
Material	Stainless Steel-304

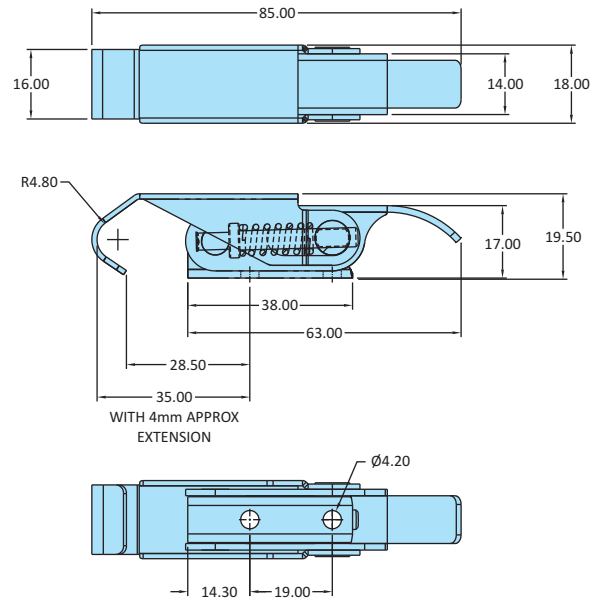
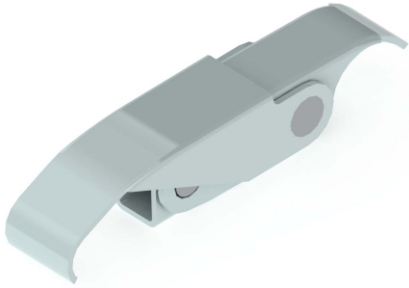

Light Duty
Non-Adjustable Claw Latch

Model No	PAH-50-1546
Weight	0.020 Kgs
Holding Capacity	X - 0.50 kN
Material	Steel
Finish	Zinc Plated
Model No	PAH-50-1546-SS
Material	Stainless Steel-304

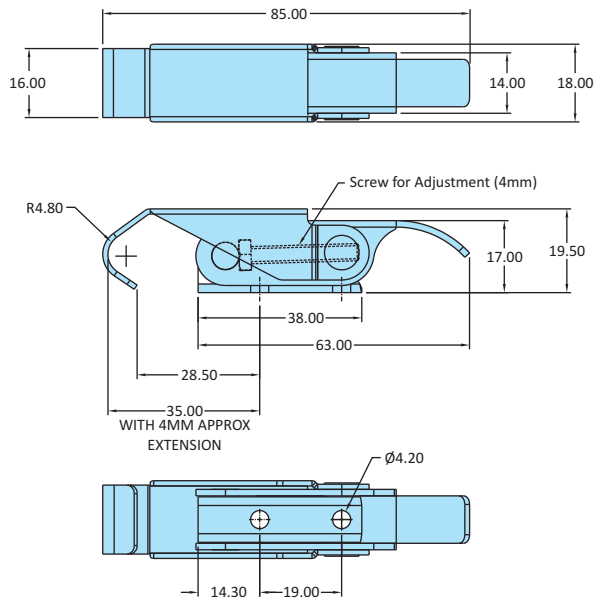
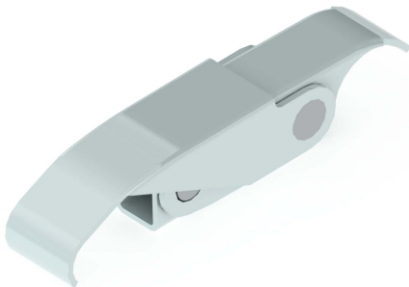

Medium Duty
Non-Adjustable Claw Latch

Model No	PAH-97-50-114
Weight	0.050 Kgs
Holding Capacity	X - 0.74 kN
Material	Steel
Finish	Zinc Plated
Supplied with Hook	FH-97-50-114
Model No	PAH-97-50-114-SS
Material	Stainless Steel-304
Supplied with Hook	FH-97-50-114-SS

