

Pneumatic Swing Clamp

Lower Flange Version-Right Swing

- No Fixture hole required
- Cylinder can be bolted directly to the fixture
- Easiest mounting preparation in the swing clamp line
- Square flange design enables clamping at all four sides of the clamp
- Allows extra large parts to be clamped

Material	Aluminum Alloy Body
Finish	Black Anodizing
Acting Type	Double Acting
Force	16 - 140 kgs
Total Stroke	26 - 29 mm
Working Pressure	4 - 7 Bar
Swivel Angle	90° ±2°

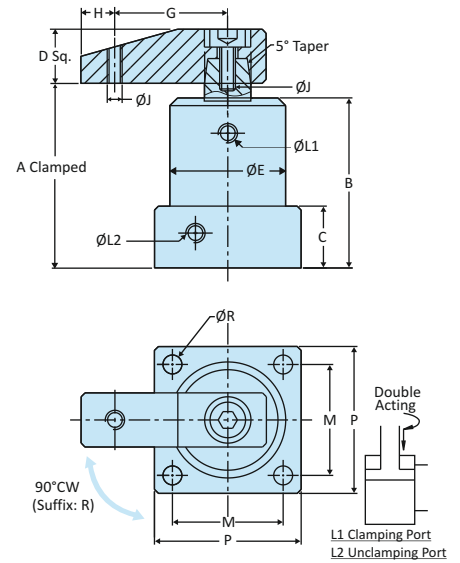

Model No	Weight Kgs	Dimensions																
		Piston Dia.	Bore Dia.	Swing Stroke	Clamping Stroke	Force in Kgs (5 kg/cm ²)	A Clamped	B	C	D Sq.	E	G	H	J	L	M	P	R
SC-25-PLF-R	0.400	14	25	12	14	16	69.5	65.5	23	16	35	30	8	M8 x 1.25	M5 x 0.8	30	40	4.5
SC-32-PLF-R	0.700	16	32	12	14	30	76.5	71	23	19	50	50	9	M8 x 1.25	1/8 PT	44	54	6.5
SC-40-PLF-R	0.850	16	40	12	15	50	79	75	26	19	55	50	9	M8 x 1.25	1/8 PT	48	58	6.5
SC-50-PLF-R	1.300	20	50	14	15	85	84	80	26	25.4	65	70	10	M10 x 1.5	1/8 PT	55	68	8.5
SC-63-PLF-R	1.800	20	63	14	15	140	90	86	30	25.4	75	70	10	M10 x 1.5	1/8 PT	64	80	8.5

Pneumatic Swing Clamp

Lower Flange Version-Left Swing

- No Fixture hole required
- Cylinder can be bolted directly to the fixture
- Easiest mounting preparation in the swing clamp line
- Square flange design enables clamping at all four sides of the clamp
- Allows extra large parts to be clamped

Material	Aluminum Alloy Body
Finish	Black Anodizing
Acting Type	Double Acting
Force	16 - 140 kgs
Total Stroke	26 - 29 mm
Working Pressure	4 - 7 Bar
Swivel Angle	90° ±2°

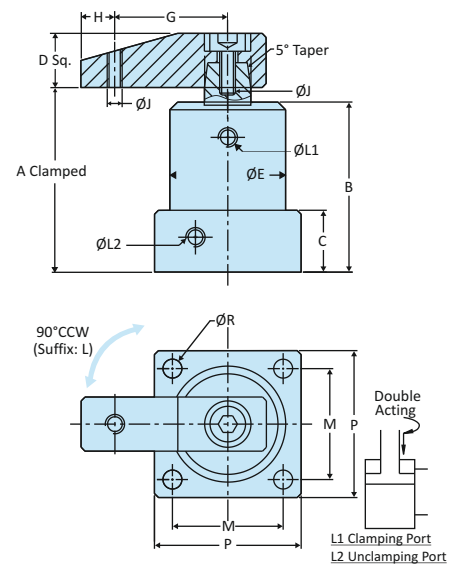

Model No	Weight Kgs	Dimensions																
		Piston Dia.	Bore Dia.	Swing Stroke	Clamping Stroke	Force in Kgs (5 kg/cm ²)	A Clamped	B	C	D Sq.	E	G	H	J	L	M	P	R
SC-25-PLF-L	0.400	14	25	12	14	16	69.5	65.5	23	16	35	30	8	M8 x 1.25	M5 x 0.8	30	40	4.5
SC-32-PLF-L	0.700	16	32	12	14	30	76.5	71	23	19	50	50	9	M8 x 1.25	1/8 PT	44	54	6.5
SC-40-PLF-L	0.850	16	40	12	15	50	79	75	26	19	55	50	9	M8 x 1.25	1/8 PT	48	58	6.5
SC-50-PLF-L	1.300	20	50	14	15	85	84	80	26	25.4	65	70	10	M10 x 1.5	1/8 PT	55	68	8.5
SC-63-PLF-L	1.800	20	63	14	15	140	90	86	30	25.4	75	70	10	M10 x 1.5	1/8 PT	64	80	8.5